

---

# MANUAL AND INSTRUCTION

---

## WESTBO WeRa M2



Westbo of Sweden

Please note and observe all warnings and safety notes. Always use original replacement parts. Ignoring these operating guidelines will void any liability and warranty entitlements.



### WARNING!

This icon indicates a potentially dangerous situation. Ignoring this warning may result in serious injury or even death.



### CAUTION!

This icon signals a possible hazardous condition. Failure to heed this caution could lead to property damage or personal injury.



### NOTE!

Offers additional advice on operating the stove and provides helpful information.



### ENVIRONMENT!

Sections highlighted with this symbol contain guidance on environmentally responsible operation and relevant environmental laws and regulations.

The installer and user must carefully review the operating manual before setting up and operating the stove.

When installing or connecting the stove, it is important to follow:

- Building regulations
- Technical documentation supplied with the stove.
- Local regulations as well as all relevant national and European standards

### When receiving the stove

When the stove is received it is important to check the goods to see that the stove is not damaged during transportation. Damages should be notified to the freight company immediately.

### Inspection of the smoke pipe.

A good piece of advice by doing the installation to existing chimney is to contact the chimney sweeper before installation.

### Connection to new chimney.

Follow the instructions from the chimney supplier.

### Suitable Chimney

The appliance must be connected to a chimney that complies with the requirements of EN 15287-1, EN 15287-2, and EN 13384-1. The chimney must be appropriately sized and constructed to ensure safe and efficient operation of the appliance.

### Proof of Proper Function

Before initial operation, the installer must verify that the chimney is functioning correctly. This includes checking for adequate draught and ensuring that the chimney is free from obstructions. A professional chimney sweep should perform this verification and provide documentation confirming the chimney's suitability for use with the appliance.

### Floor Load-Bearing Capacity and suitable measures

Ensure the floor can support the appliance's weight. Before installation, have the load-bearing capacity of the floor assessed by a qualified installer. If necessary, take suitable measures (e.g., reinforced base, protective plates) to guarantee safe and stable installation.

### Connection to new chimney.

Follow the instructions from the chimney supplier. The appliance is NOT suitable for installation in a shared flue system.

### Installation Room Requirements

The installation room must provide sufficient space, structural stability and ventilation to ensure safe and efficient operation of the appliance. Floors, walls and ceilings must withstand heat radiation and the weight of the appliance.

Do not install the appliance in hallways, staircases or other escape routes. Avoid rooms where ventilation is insufficient or where combustible materials are stored too close to the appliance.

Installation must comply with all applicable national building regulations and safety standards.



### CAUTION! Floor protection

The floor protection prevents the floor in front of the stove from sparks. Check your local regulations by your domestic authorities. The floor protection could consist of 0,7 mm metal sheet, glass, tiles, natural stone etc.

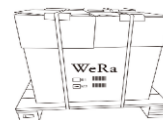

Cut the strap and remove the carton.

**Fire up**

We recommend that you use fire starters that you find at your dealer. By using them it will be a quick fire of the wood and a cleaner combustion. Never use ignition fluid.

Use approximately 1,5-2 kilo of dry wood logs. Place them like picture nr 1, two logs in a bottom and small on the top.

**Mass of basic firebed:****Specification of the maximum filling level/high with fuel:**

Then add two or three fire starters on top and fire up. Let the door on the stove be ajar for a while. Close the door when the fire start to grow. By doing this it will be a quick flashover of the fire which minimizes soot coating on the glass.

**Continuous firing**

It is important to have a correct temperature in the stove to get the most out of your product. When the stove is used in the right way, the smoke should not be visible.

The appliance is capable of intermittent operation according to EN 16510.

Adjust the supply air slider relative to the chimney draft. It should burn well, if it is strangled too much, there is a risk of soot coating in the fireplace as well as soot on the glass. Set the slider at least half open to achieve nominal output.

More fuel should be added to the fire when the flames from the previous burning off phase have just gone out.

To achieve nominal heat output, place the new logs (total weight: 1.35-1.5 kg) in the center (approx. 1 cm apart) of the firebox grate. After adding new firewood, the air slider should be fully opened for a short while to assist ignition. (at most 3 minutes).

The typical refueling interval is 40-45 minutes during nominal output.

**WARNING!**

Do not operate the appliance under adverse flue draught conditions or adverse weather conditions.

**WARNING!**

The fireplace must not be modified!

**WARNING!**

Never use spirits, petrol, or other flammable fluids to light the stove, gasoline, gasoline-type lantern fuel, kerosene, charcoal lighter fluid, ethyl alcohol or similar liquids to start or "reignite" a fire in the heater. Keep all such liquids well away from the heater while it is in use

Do not use the appliance as an incinerator.

Only use fuels recommended by the manufacturer. Do not burn unsuitable materials (see chapter wood handling)

Ensure adequate combustion and ventilation air. Keep all air intake grilles free from obstruction during operation.

Ensure adequate protection against the risk of fire inside and outside the appliance's heat radiation area.

Parts of the appliance, especially external surfaces, become hot during operation. Keep children away and take care to avoid burns.

**WARNING!**

Keep the combustion chamber and ashpit cover closed at all times, except during ignition, refueling, or removal of ash and residue, to prevent fume spillage. Do not operate with an open combustion chamber unless the appliance is designed for it.

**CAUTION!****Combustion air supply**

This appliance requires a dedicated supply of combustion air. Provide either a permanent air supply to the room or connect the appliance to an external air inlet. Air inlets and ducts must be sized by the installer and kept free from obstruction. Position air inlet grilles so that they cannot be blocked or closed accidentally. In airtight or low-energy buildings, an external combustion air connection is recommended.

**CAUTION!****Other combustion appliances in the same room/connected space**

If other combustion appliances are operated in the same room or an adjoining space, sufficient combustion air must be available for *all* appliances. Always consult the chimney sweep to check whether simultaneous operation is permitted.

**CAUTION!**

The door handle can become hot during operation. When adding more wood, protect your hands with the oven gloves included.

**CAUTION!**

Please ensure that the logs are inserted with sufficient distance (at least 5 cm) from the stove windows

The air slider must not be left in the heating-up position once the warming up phase is complete.

**CAUTION!****Operation of exhaust air devices like extractor hoods, bathroom fans, tumble dryers**

Exhaust air devices can create negative pressure that impairs chimney draught and may cause smoke to enter the room. Do not operate such devices at the same time as the stove unless a safe combustion air supply and, where required, an approved safety interlock is installed.

### Emptying the ashes

As a safety precaution, please make sure that you only dispose of ashes once they are cold.

### Cleaning

There are special detergents for cleaning the glass hatch at your retailer. Do not use abrasive detergents.

### Smell

At the first firing, a certain smell might occur. This due to the coating on the sheet metal is burnt off. The smell disappears after a couple of bonfires.

You can vary the thermal output of your stove by adjusting the quantity of fuel used.



### NOTE!

Do not attempt to slow down the combustion by reducing the air supply. When heating with wood, this can result in an incomplete burning process and pose the risk of an explosive like combustion of the accumulated wood gases (deflagration).

During the transition seasons (spring/ autumn), outdoor temperatures in excess of 16° can cause disruptions to the airflow in the chimney. If at this temperature a draught cannot be created by burning a piece of paper or a small piece of wood (a pilot fire), no fire should be lit. To avoid room heat loss, close the air slide after the heating process has been completed and the combustion process is fully finished.



### CAUTION!

It is important to get a quick flashover of the wood, do not close the glass hatch before the wood has started to burn.

If the fire is smoldering it could in worse cases cause a gas explosion, which could damage your stove.

When firewood is replenished, carefully open the glass hatch so that smoke rashes are avoided. Never fill up the firewood as long as it burns well.



### CAUTION!

To prevent adverse effects on health, nobody should stay in the room(s) during this process unless absolutely necessary. Make sure the room is well-ventilated and open the windows and outside doors. If needed, use a fan for faster air circulation.

If the maximum temperature is not reached during the first heating operation, you may notice an odor for a short period of time the next time the stove is used as well.



### WARNING!

#### Chimney fire

In case of chimney fire, all doors and air controls must be closed. If necessary, contact the authorities.

After an eventual fire, the chimney must be inspected by the chimney sweeper.

**The appliance must be cleaned and maintained regularly to ensure proper functioning.  
Ash, soot and other deposits must be removed.**

**Recommended cleaning procedures (Only in cold condition)**

- **Removing ash:** Allow the ash to cool down completely before removing it. Use a metal ash container with a tightly fitting lid.
- **Cleaning the interior:** Use a vacuum cleaner with an ash attachment or a soft brush to remove ash and soot residues from the firebox.
- **Cleaning the glass:** Clean the stove door regularly with a damp cloth. For stubborn deposits, suitable stove glass cleaners may be used.
- **Flue and chimney:** Have the flue pipe and chimney professionally cleaned at least once a year to ensure safe exhaust gas discharge.
- **Important:** Ensure that sufficient access is provided to allow regular cleaning of the appliance, the flue gas connector and the chimney flue.
- Before re-lighting the appliance after a prolonged shutdown, always check that the flue and air passages are free from blockage.

**Including**

- 4 Legs and screws
- 6 Chamotte bricks
- 1 Air box
- 1 Handle
- 1 Smoke pipe 125 mm in diameter

**Chamotte bricks**

Combined with the stove there are six Chamotte bricks.

S1 och S2 - Side bricks

S 5 - Bottom brick

S 6 - Rear brick

S 3 -and S 4 - Baffle plates

Place the bricks shown on this page.

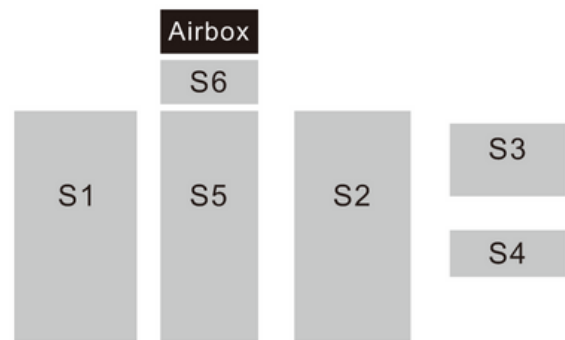

Legs and Chamotte bricks must be mounted on the firebox. Start to assemble the four legs incl. radiationsheet (see picture no 1,2,3.) on the body. Then follow the steps below.



Picture no 1

Picture no 2

Picture no 3

1. Disassemble the top plate from the firebox and lift it off. First, place the left side brick (S1) in the firebox.
2. Then insert the second side brick (S2). Be careful on the orientation of the side stones so the airholes are in correct position.
3. Then insert the bottom brick (S5) and the rear brick (S6).
4. Place the baffle plates (S3) and (S4) towards the back so the gap for the smoke is in the front. Reassemble the top plate.

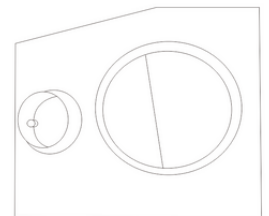

The fireplace is now ready.

Install the handle. In some cases, a smaller piece of the side brick (S2) needs to be knocked away in order to that handles and door should be able to close correctly.

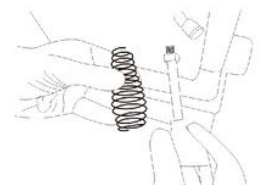
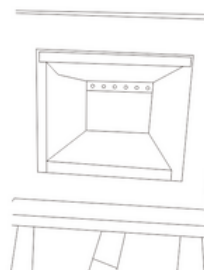

## Troubleshooting and Safe Shutdown

### Simple fault finding:

<u>Problem</u>	<u>Possible Causes</u>
Wood does not ignite or ignites slowly	- Wood is too thick - Wood is damp - Inadequate air supply
Wood smoulders, burns without a bright flame, or goes out	- Wood is damp - Insufficient air supply - Butterfly valve is closed too tightly - Outside temperature is too high
Excessive soot; heat-resistant panels get dirty	- Outside temperature is too high - Inadequate air supply - Too little wood causes the combustion chamber to remain cold
Firebox window becomes sooty	- Damp wood - Inadequate secondary air supply - Firebox door is not tightly sealed - Weak chimney draught
Wood burns too quickly	- Chimney draught is too strong - Logs are too small - Control elements incorrectly set
Smoke escapes into the room during operation	- Inadequate air supply or closed butterfly valve - Chimney cross-section too narrow - Soot buildup in stove pipe or flue - Wind blowing down chimney - Exhaust fans (kitchen, bathroom) causing negative pressure
Chimney becomes wet / creosote forms / condensate leaks	- Damp wood - Flue gases or chimney are too cold - Chimney cross-section is too wide
Fire burns well, but stove does not get warm	- Chimney draught is too strong - Air sliders are incorrectly set - Chimney draught is too weak - Chimney cross-section too wide or narrow
Smoke escapes when firebox door is opened	- Fire is burning too strongly - Door opened too quickly - Exhaust fans (e.g., in the bathroom or kitchen) are creating negative pressure in the living room, pulling smoke out of the stove. - The butterfly valve is closed, restricting airflow.

### Overheating or abnormal operation:

- **Immediate Action:** Keep the appliance door closed and allow the appliance to cool naturally.
- **Do not attempt to remove burning fuel** from the combustion chamber.
- **Do not completely close the air supply**, as this can cause flashbacks or incomplete combustion.

### Smoke spillage or unusual behavior:

- Ensure the room is ventilated.
- Stop using the appliance if smoke enters the room or abnormal operation continues.

### Professional Assistance:

- Contact a qualified technician if the cause of the fault cannot be identified or resolved safely.



### NOTE!

Always follow the manufacturer's instructions to prevent risk of fire or injury.

**ENVIRONMENT!****Disassembly, Recycling, and Disposal at End-of-Life****Disassembly**

Before disassembling the appliance, ensure that it is disconnected from all power sources and that any residual heat has dissipated. Use appropriate tools and personal protective equipment to prevent injury.

**Recycling**

The appliance contains materials that can be recycled, including metals, plastics and glass. Separate these materials according to local recycling guidelines to facilitate proper processing. Avoid mixing recyclable materials with non-recyclable waste.

**Disposal**

Do not dispose of the appliance in household waste. Contact local waste management authorities to arrange for proper disposal. Many regions offer collection services for large appliances or have designated drop-off points.

**Environmental Considerations**

Improper disposal of appliances can lead to environmental pollution and resource wastage. By following proper disassembly, recycling and disposal procedures, you contribute to environmental conservation and comply with applicable regulations.

**ENVIRONMENT!****Storage**

The splitted wood logs should be stored for 1-2 years before usage. If the wood is put in piles it will dry faster. Before use, store the wood in room temperature. Please keep in mind that the wood during Autumn and Winter absorbs moist from the air.

**Moisture**

To avoid environmental problems and to get the best fueling economy, the wood logs must be dried before use.

By using moist wood logs, large amount of the heat will be used to evaporate the water. The stove will therefore not be warm. This is of course uneconomic and there will be soot on the glass hatches, inside the stove and in the chimney. The environment will also be contaminated.

**It is absolutely forbidden to fire:**

Painted, pressure-treated or glued wood. Neither is chipboard, plastic, or treated paper suitable to fire. The substances contained in these products are harmful both to the environment and to the stove. Even the chimney can be attacked if you use material mentioned above.

Simply put, fire only clean wood logs.

**Recommended Fuel**

Only use dry, seasoned hardwoods with a moisture content of less than 20%.

Recommended species include beech and birch

WeRa M2

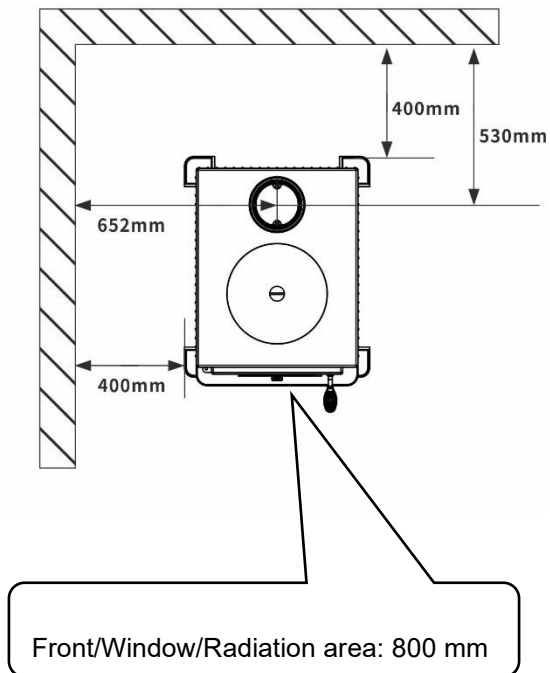

### Change of front glass

Remove the clips that hold the glass in place and then install the new glass. Sealing string, replace if necessary.

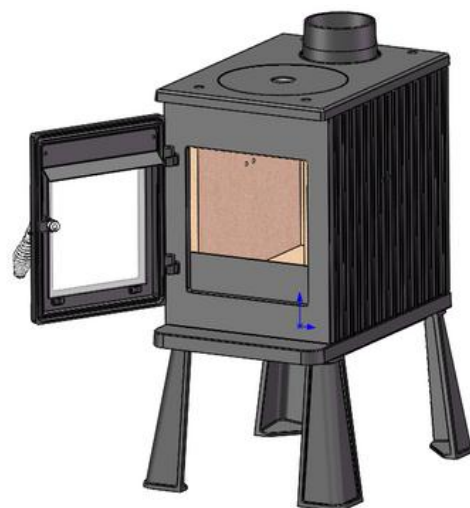

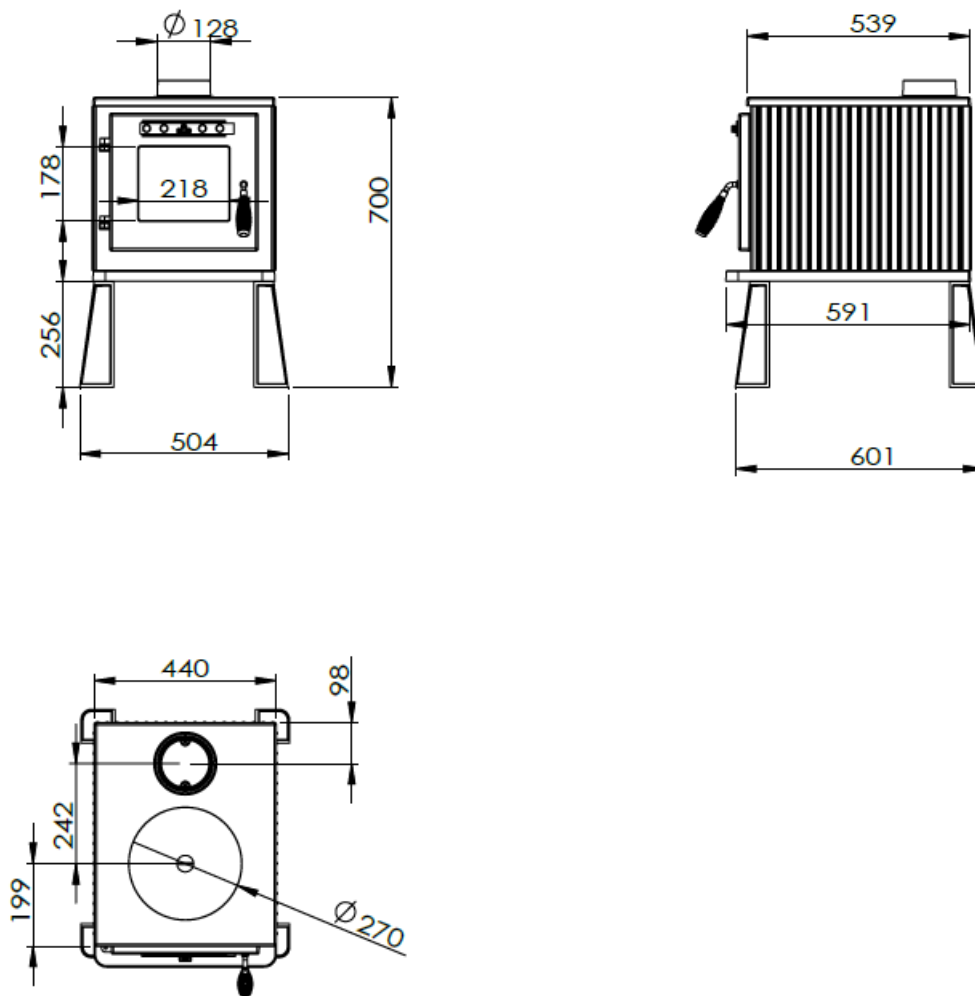

Weight	150 kg
Height	700 mm
Width	504 mm
Deep	601 mm
Cooking plate	270 mm diameter
Smoke pipe	125 mm diameter
Material	Cast iron
Nominal output	7,0 kW
Efficiency	80%
Distance to combustible wall/side	400 mm
Front/Window/Radiation area:	800 mm
CE-approved	EN 16510

## Technical datasheet accord. EN 16510-1:2022

Manufacturer	Westbo of Sweden AB Industrigatan 8, 333 75 Reftele SWEDEN
E-Mail	info@westbo.net
Type and/or model number or name:	WeRa M2
Technical specification	EN 16510-2-1:2022
Type of fireplace	Typ B
Usable fuels	Wood logs

Parameter	Unit	Value	
$P_{nom}$	kW	7,0	Nominal heat output according to manufacturer
$P_{SHnom}$	kW	7,0	Nominal room heating output
$P_{Wnom}$	kW	NPD	Nominal water heating output
$P_{part}$	kW	NPD	Partial load heat output
$P_{SHpart}$	kW	NPD	Partial load room heating output
$P_{wpart}$	kW	NPD	Partial load water heating output
$P_{slow}$	kW	NPD	Low load heat output
$P_{SHslow}$	kW	NPD	Low load room heating output
$P_{wslow}$	kW	NPD	Low load water heating output
$P_{acc in}$	kW	NPD	Storage heat input
$T_{acc in}$	°C	NPD	Temperature at the inlet of the separate heat exchanger
$\zeta_{acc}$	Pa	NPD	Flow resistance of the separate heat exchanger
$\eta_{nom}$	%	80,0	Efficiency of the combustion unit at nominal heat output
$\eta_{part}$	%	NPD	Efficiency of the combustion unit at partial load heat output
$\eta_s$	%	65	Seasonal space heating efficiency of the combustion unit at nominal heat output
EEI	-	106	Energy efficiency index
$CO_{nom} (13 \% O_2)$	mg/m <sup>3</sup>	1500	CO emission at an oxygen content of 13% at nominal heat output
$CO_{part} (13 \% O_2)$	mg/m <sup>3</sup>	NPD	CO emission at an oxygen content of 13% at partial load heat output
$CO_{slow} (13 \% O_2)$	mg/m <sup>3</sup>	NPD	CO emission at an oxygen content of 13% at low load heat output
$NO_{Xnom} (13 \% O_2)$	mg/m <sup>3</sup>	200	NOx emission at an oxygen content of 13% at nominal heat output
$NO_{Xpart} (13 \% O_2)$	mg/m <sup>3</sup>	NPD	NOx emission at an oxygen content of 13% at partial load heat output
$NO_{Xslow} (13 \% O_2)$	mg/m <sup>3</sup>	NPD	NOx emission at an oxygen content of 13% at low load heat output
$OGC_{nom} (13 \% O_2)$	mgC/m <sup>3</sup>	120	Hydrocarbon emission at an oxygen content of 13% at nominal heat output
$OGC_{part} (13 \% O_2)$	mgC/m <sup>3</sup>	NPD	Hydrocarbon emission at an oxygen content of 13% at partial load heat output
$OGC_{slow} (13 \% O_2)$	mgC/m <sup>3</sup>	NPD	Hydrocarbon emission at an oxygen content of 13% at low load heat output
$PM_{nom} (13 \% O_2)$	mg/m <sup>3</sup>	40	Particle emissions at an oxygen content of 13% at nominal heat output
$PM_{part} (13 \% O_2)$	mg/m <sup>3</sup>	NPD	Particle emissions at an oxygen content of 13% at partial load heat output
$PM_{slow} (13 \% O_2)$	mg/m <sup>3</sup>	NPD	Particle emissions at an oxygen content of 13% at low load heat output
$p_{nom}$	Pa	12	Minimum delivery pressure at nominal heat output
$p_{part}$	Pa	NPD	Minimum delivery pressure at partial load heat output
$p_{slow}$	Pa	NPD	Minimum delivery pressure at low load heat output

$p_w$	bar	NPD	Maximum permissible water operating pressure
$d_R$	mm	400	Minimum distances from the back to flammable materials
$d_s$	mm	400	Minimum distances from the sides to flammable materials
$d_c$	mm	750	Minimum distances from the top to combustible materials in the ceiling
$d_P$	mm	800	Minimum distances from the front to flammable materials
$d_F$	mm	560	Minimum distances from the front to combustible materials in the lower front radiation area
$d_L$	mm	560	Minimum distances from the front to combustible materials in the lateral front radiation area
$d_B$	mm	0	Minimum distances below floor level (excluding feet) to combustible materials
$d_{non}$	mm	NPD	Minimum distances to non-combustible walls
$s$	mm	0	Protective insulation according to manufacturer's specifications
$e_{lSB}$	kW	NPD	Consumption of auxiliary electrical energy at partial load heat output
$e_{lmax}$	kW	NPD	Consumption of auxiliary electrical energy at nominal heat output
$e_{lmin}$	kW	NPD	Consumption of auxiliary electrical energy at partial load heat output
$E_{,f}$	V,Hz	NPD	Supply voltage
$W_{max}$	W	NPD	Maximum electrical power consumption
$T_{snom}$	°C	266	Temperature at Exhaust pipe diameter at nominal heat output
$T_{spart}$	°C	NPD	Temperature at the exhaust pipe diameter at partial load heat output
T-Klasse	-	T400 - G	Chimney designation according to the relevant chimney standard
$\phi_{f,g,nom}$	g/s	8,0	Exhaust gas mass flow rate at nominal heat output
$\phi_{f,g,part}$	g/s	NPD	Exhaust gas mass flow rate at partial load heat output
$V_h$	m <sup>3</sup> /h	NPD	Room heat loss when the appliance is not in operation
CON oder INT	-	INT	Whether the appliance is suitable for continuous burning (CON) or intermittent burning (INT)
$d_{out}$	mm	Ø 125	Exhaust pipe diameter
L,H,W	mm	504x700x601	Overall dimensions of the appliance (length, height, width)
$m$	kg	150	Mass of the appliance
$m_{chim}$	kg	80	The maximum load-bearing capacity of a chimney
		Read and follow the operating instructions!	

**Declaration of performance according to Regulation (EU) 305/2011**

Information according to (EU) 305/2011		Registration by the manufacturer			
Unique identification code of the product type		WeRa M2			
Intended use(s)		Space heating in residential buildings			
Manufacturer / trade mark		Westbo of Sweden AB Industrigatan 8, 333 75 Reftele SWEDEN			
E-Mail		info@westbo.net			
Authorised representative		Westbo of Sweden AB Industrigatan 8, 333 75 Reftele SWEDEN			
E-Mail		info@westbo.net			
System(s) of assessment and verification of constancy of performance of the construction product		System 3			
The notified test laboratory has performed the initial test according to system 3. Notified body(ies)		NB-1625	Rhein-Ruhr Feuerstätten Prüfstelle GmbH		
		Im Lipperfeld 34b, 46047 Oberhausen, DEUTSCHLAND			
		Test report number	RRF – 40 21 5845-1		
Harmonised technical specifications		EN 16510-2-1:2022			
<b>Essential characteristics</b>					
<b>Mechanical resistance and stability</b>					
Load bearing capacity		80 kg			
<b>Safety in case of fire</b>					
Protection of combustible materials		Minimum distance to combustible materials – bottom d <sub>B</sub> = 0 mm			
		Minimum distance to combustible materials – floor in front d <sub>F</sub> = 560 mm			
		Minimum distance to combustible materials – ceiling d <sub>C</sub> = 750 mm			
		Minimum distance to combustible materials – rear d <sub>R</sub> = 400 mm			
		Minimum distance to combustible materials – side d <sub>S</sub> = 400 mm			
		Minimum distance to combustible materials – side radiation area d <sub>L</sub> = 560 mm			
		Minimum distance to adjacent combustible materials – front radiation area d <sub>P</sub> = 800 mm			
		Material type and thickness of the protective insulation material s = 0 mm			
		<b>Hygiene, health and environment</b>			
		<i>Emissions at nominal heat output</i>			
		Carbon monoxide (CO)		1500 mg/m <sup>3</sup>	
		Nitrogen oxides (NO <sub>x</sub> )		200 mg/m <sup>3</sup>	
Organic gaseous carbon (OGC)		120 mg/m <sup>3</sup>			

Particulate matter (PM)	40	mg/m <sup>3</sup>
<i>Emissions at part load heat output</i>		
Carbon monoxide (CO)	NPD	mg/m <sup>3</sup>
Nitrogen oxides (NO <sub>x</sub> )	NPD	mg/m <sup>3</sup>
Organic gaseous carbon (OGC)	NPD	mg/m <sup>3</sup>
Particulate matter (PM)	NPD	mg/m <sup>3</sup>
<b>Information according to (EU) 305/2011</b>	<b>Registration by the manufacturer</b>	
<b>Safety and accessibility in use</b>		
<i>Data for installation to a chimney at nominal heat output</i>		
Flue gas outlet temperature	266	°C
Minimum flue draught	12	Pa
Flue gas mass flow	8,0	g/s
<i>Data for installation to a chimney at part load heat output</i>		
Flue gas outlet temperature	NPD	°C
Minimum flue draught	NPD	Pa
Flue gas mass flow	NPD	g/s
<i>Data for installation to a chimney regarding fire safety on safety test heat output</i>		
Fire safety of installation to the chimney	T400 - G	
<b>Energy economy and heat retention</b>		
<i>Appliance's thermal output and energy efficiency at nominal heat output</i>		
Space heat output	7,0	kW
Water heat output	NPD	kW
Efficiency	80	%
<i>Appliance's thermal output and energy efficiency at part load heat output</i>		
Space heat output	NPD	kW
Water heat output	NPD	kW
Efficiency	NPD	%
<i>Space heating efficiency</i>		
Seasonal space heating efficiency at nominal heat output	65 %	
Energy Efficiency	Energy Efficiency Index (EEI)	106
	Energy efficiency class	A
Electric power consumption at nominal heat output	NPD	kW
Electric power consumption at part load heat output	NPD	kW
Power consumption in standby mode	NPD	kW
<b>Sustainable use of natural resources</b>		
Environmental sustainability	NPD	
The performance of the product identified above is in conformity with the set of declared performance.		
This declaration of performance is issued, in accordance with regulation (EU) No 305/2011, under the sole responsibility of the manufacturer identified above.		

**Signed on behalf of the manufacturer**

Mattias Gunnarsson, CEO  
 Westbo of Sweden AB  
 2026-02-18



**EC declaration of conformity**

The Manufacturer

**Westbo of Sweden AB  
Industrigatan 8, 333 75 Reftele  
SWEDEN**

declares under its sole responsibility that the product for space heating in residential buildings with the trade name

**WeRa M2**

is in conformity with the requirements of:

- **the Directives on the setting of requirements for energy-related products (Ecodesign) 2009/125/EC and (EU) 2015/1185**
- **Delegated Regulation (EU) 2015/1186 with regard to the energy labelling of local space heaters**

and complies with the following harmonised standard:

**EN 16510-2-1:2022**

The product was tested for compliance with the requirements of the standard by the Notified Body:

**NB-1625 Rhein-Ruhr Feuerstätten Prüfstelle GmbH  
Im Lipperfeld 34b, 46047 Oberhausen, DEUTSCHLAND**

With the type test report, no:

**RRF – 40 21 5845-1**

Important notes on installation and maintenance:

Please read and follow the installation and operating instructions! Distances to combustible components and fire protection must be observed! Sufficient combustion air must be able to flow to the fireplace! Heating appliances with water technology may only be put into operation if all safety devices are operational and functional!

Mattias Gunnarsson, CEO  
Westbo of Sweden  
2025-09-22



# WARRANTY

Westbo of Sweden has a 15-year stove casting warranty and a 1-year warranty concerning natural wear and tear of articles of consumption such as firebricks, vermiculite, grates, glass, handles and rope seal.

The warranty is only valid if the stove has been used in a proper way according to the instructions and will not be valid if any extreme or careless handling has occurred like overheating, wrong fuel or too much wood etc.

Westbo of Sweden is obligated to provide new parts/stove if any defects covered by the warranty occurred but takes no responsibility for removal or installation costs for the exchange.

The warranty covers only the product, and the buyer is not entitled to compensation for any personal or property damage.



Yours sincerely

Mattias Gunnarsson  
Managing director  
Westbo of Sweden AB